



C.P.T.

Präzisions Werkzeuge

x-treme thread cutting™



Machine Taps Kit

English

Machine Taps Kit

ISO metric coarse M - DIN13

DIN 371

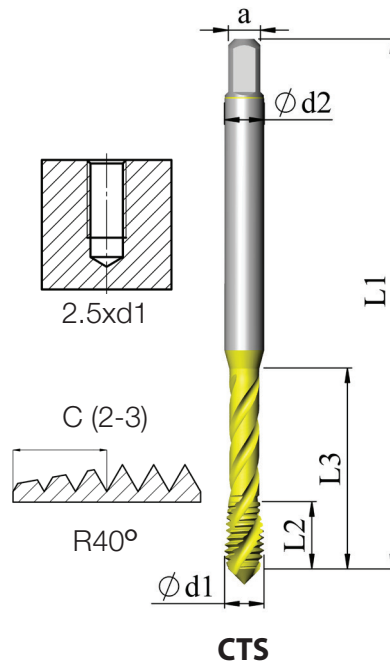

ISO	P	M	K	N	S	H
XT5 Grade	●	●	●	●		

Ordering Code	d1	Pitch mm	Item Description	d2	L1	L2	L3	a	
KCTS-ISO-XT5	M3	0.5	CTS D371 C M3x0.5 6H XT5	3.5	56	5	18	2.7	2.50
	M4	0.7	CTS D371 C M4x0.7 6H XT5	4.5	63	7	21	3.4	3.30
	M5	0.8	CTS D371 C M5x0.8 6H XT5	6.0	70	8	25	4.9	4.20
	M6	1.0	CTS D371 C M6x1.0 6H XT5	6.0	80	10	30	4.9	5.00
	M8	1.25	CTS D371 C M8x1.25 6H XT5	8.0	90	13	35	6.2	6.80
	M10	1.5	CTS D371 C M10x1.5 6H XT5	10.0	100	15	39	8.0	8.50

Order example: KCTS-ISO-XT5



CPT GmbH

Danziger Straße 1, 71691 Freiberg am Neckar
 Tel: +49 (0) 7141 / 14239-00, Fax: +49 (0) 7141 / 14239-20
 E-Mail: info@cpt-werkzeuge.de | www.cpt-werkzeuge.de